



Safety Advice Sheet

BEFORE YOU BEGIN:

- Please read and understand the instructions prior to assembly. Incorrect installation of this product could possibly result in personal injury or physical damage.
- WallBeds Australia recommends that eye protection is worn when assembling the product.
- WallBeds Australia recommends two people to safely assemble and install the wall bed - It is not recommended you try to install this bed on your own.
- The wall bed **MUST** be securely fastened to the wall. Failure to do so will cause the bed to tip over & may cause damage to the cabinet or serious personal injury.
- Whilst these products are DIY it is recommended the wall bed be installed by a qualified tradesperson if you are not comfortable with the installation of this product.

WallBeds Australia is not responsible for any damages or injuries incurred by incorrect installation.



Alpha Flat Pack Steel Bed Frame Assembly Instructions

Stocked in: Single Double
 Queen King

One universal bed frame which can be used to construct a Single, Double, or Queen WallBeds.

It can be mounted in either vertical or horizontal modes.

A lightweight universal structural steel bed frame with double overlap steel stiffeners completed with a fold-away leg system. The frame is designed to exceed the strength of wood or aluminum. The Alpha frame may be used in residential and commercial applications.

Designed to Exceed International ISO 9002
Standards for residential specifications

Carton Contents for Steel Bed Frame (#SBF)

Note: Each Single, Double, Queen or King Steel Bed Frame carton contains one complete necessary hardware to complete the bed frame you have chosen. Not all bags listed below relate to every size frame.

| Stock# | Qty. | Item | Comments |
|--|-------|-------------------------------------|--|
| 1999E | 2 | Frame End Sections | Identical Head & Foot |
| 1999S | 2 | Frame Side Sections | Identical Right or Left <input type="checkbox"/> |
| S456 (SK7) | 3 (5) | Stiffeners - Bed Face (King Size) | Space evenly between Frame Sides <input type="checkbox"/> |
| LG-13 | 2 | Fold-away Legs | One Left - One Right <input type="checkbox"/> |
| LR | 1 | Leg Connector Rod | Stabalizes and Eases Leg Operation <input type="checkbox"/> |
| (Hardware Bag #3) | | | |
| 1214 | 14 | Bolt 10-24 x 1/2" Black | Bolt Frame corners <input type="checkbox"/> |
| 1213 | 2 | Bolt 10-24 x 1 1/4" Black | Bolt Leg Stop Foot corners <input type="checkbox"/> |
| 1218 | 16 | Nut 10-24 x Black Nylock | Use with #1214 & #1213 <input type="checkbox"/> |
| 1226 | 4 | Angle 1"x1"x1 3/4" Black | Use inside Frame corners <input type="checkbox"/> |
| 1223 | 2 | 1/2" x 3/4" Round Black Cylinder | Use with #1213 as Leg Stop <input type="checkbox"/> |
| (Hardware Bag #4) | | | |
| 1220 | 2 | 1 1/2" x 5/16" Black Washer | Secure Leg inside Frame <input type="checkbox"/> |
| 1222 | 2 | 1 1/2" x .765" Black Washer | Secure Leg inside Frame <input type="checkbox"/> |
| 1221 | 2 | 1 1/2" x .765" Black Nylon Washer | Between Leg & outside of Frame <input type="checkbox"/> |
| 1217 | 2 | Nut 5/16" Black Nylock | Secure Leg inside Frame <input type="checkbox"/> |
| 1210 | 2 | Bolt 1/4"-20 Black Hex Head | Attach Leg to Leg Rod <input type="checkbox"/> |
| SW1 | 2 | Star Washer for #1210 | Attach Leg to Leg Rod <input type="checkbox"/> |
| (Hardware Bag #5) | | | |
| 1228 | 1 | Nylon Web Strap with Buckle | Secure Mattress to Bed Frame <input type="checkbox"/> |
| 1229 | 2 | 3/4" x 1/4" Washer | Secure Nylon Web Strap to Bed Face Panel under Mattress <input type="checkbox"/> |
| 1224 | 2 | #8 x 5/8" Wood Screw | Secure Nylon Web Strap <input type="checkbox"/> |
| (Hardware Bag #7 - King size includes 2 bags) | | | |
| 1224 | 110 | #8 x 5/8" Wood Screw | Attach Steel Bed Frame to Bed Face <input type="checkbox"/> |
| (Hardware Bag #22) | | | |
| 1226 | 20 | 1" x 1" x 1 3/4" Black Corner Angle | Assemble Cabinets <input type="checkbox"/> |
| PS-1 | 2 | 1" x 3" Black Panel Saver | Assemble per Drawing <input type="checkbox"/> |
| | 80 | #8 x 5/8" Black Wood Screw | Attach the above <input type="checkbox"/> |

Alpha Bed Frame Project Start-Up

- Familiarise yourself with all of the components in the Alpha Bed Frame and mechanism cartons, as well as thoroughly study this manual so you may plan the steps required to complete this project.
- Study all illustrations and plan drawings. Make sure that the space available is adequate for the specified dimensions of the bed cabinet; both in the open and closed positions (see cut list pages to cross check dimensions).
- Panels should be 16mm MDF. Particle board is acceptable but with more attention given to assembly procedures and handling. This is discussed further in this manual.

Steps to Complete Project

1. Prepare all wood or laminate cabinet components.
2. Mount Lift Mechanism.
3. Install springs in Lift Mechanisms.
4. Assemble the Bed Cabinet.
5. Attach Bed Cabinet to wall.
6. Assemble Steel Bed Frame to Face/Base Panels.
7. Install the Face/Base Panel in Cabinet.
8. Install Handles, Leg Assembly, Mechanism Covers, Mattress

* Some You Tube tutorials are available from Murphy Bed for the Frame & Spring assembly.

Any cabinetry assembly shown in these clips DO NOT relate to WallBeds Australia Cabinetry instructions. These clips are a visual guide on how to assemble the Steel Frame component of the wall bed which is universal world wide. *

Alpha Bed Steel Frame Component Layout

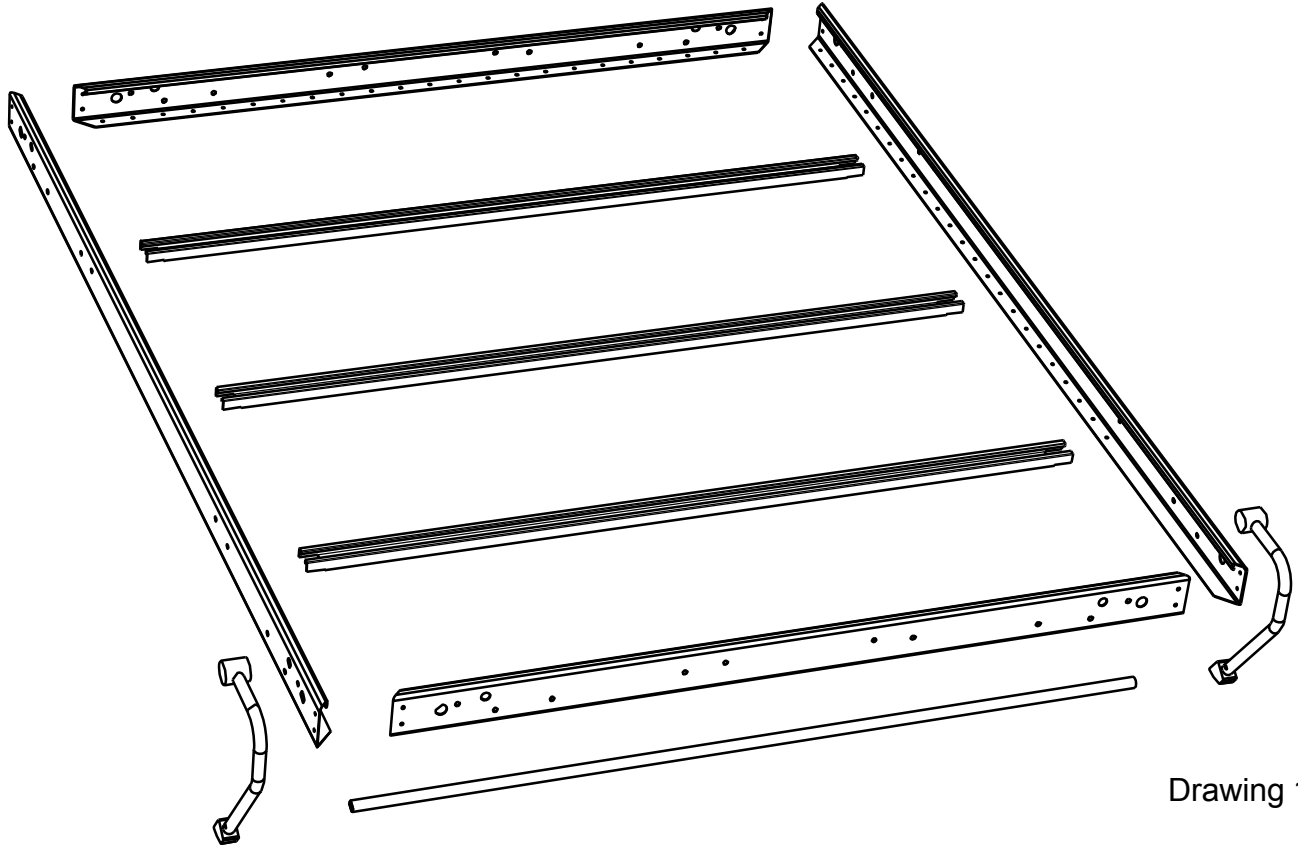

Drawing 1.

- Frame is adaptable as vertical or horizontal (side tilt) bed.



Alpha Bed Steel Frame - Vertical Bed Cabinet Cut List

Use a 100mm Kick.

| Single Bed – Finished Size | | Overall Cabinet Dimensions: 1126 w x 2087 h x 410 d | | |
|---|-----------------|---|--------|---------------------|
| Mattress size 990 x 1900 300mm max thickness | | Protrusion from wall to foot bed: 2150mm Cabinet Material: 16 MDF or Chipboard | | |
| Quantity | Description | Width | Length | Finish (Tape) Edges |
| 1 | Face/Base Panel | 1085 | 1962 | EAR |
| 2 | Side End Panels | 410 | 2087 | 1 Long |
| 1 | Headboard | 370 | 1091 | 2 Long |
| 1 | Top Panel | 390 | 1091 | 1 Long |
| 1 | Kick | 100 | 1091 | 1 Long |
| 2 | Backs | 350 | 1091 | 1 Long |
| Double – Finished Size | | Overall Cabinet Dimensions: 1505 w x 2087 h x 410 d | | |
| Mattress size 1371 x 1900 300 max thickness | | Protrusion from wall to foot bed: 2150mm Cabinet Material: 16 MDF 16 MDF or Chipboard | | |
| Quantity | Description | Width | Length | Finish (Tape) Edges |
| 2 | Face/Base Panel | 732 | 1962 | EAR |
| 2 | End Panels | 410 | 2087 | 1 Long |
| 1 | Headboard | 370 | 1473 | 2 Long |
| 1 | Top Panel | 390 | 1473 | 1 Long |
| 1 | Kick | 100 | 1473 | 1 Long |
| 2 | Back | 350 | 1473 | 1 Long |
| Queen Bed – Finished Size | | Overall Cabinet Dimensions: 1658 w x 2215 h x 410 d | | |
| Mattress size 1524 x 2032 300 max thickness | | Protrusion from wall to foot bed: 2285 Cabinet Material: 16 MDF 16 MDF or Chipboard | | |
| Quantity | Description | Width | Length | Finish (Tape) Edges |
| 2 | Face/Base Panel | 809 | 2090 | EAR |
| 2 | End Panels | 410 | 2215 | 1 Long |
| 1 | Headboard | 370 | 1626 | 2 Long |
| 1 | Top Panel | 390 | 1626 | 1 Long |
| 1 | Kick | 100 | 1626 | 1 Long |
| 2 | Back | 350 | 1626 | 1 Long |

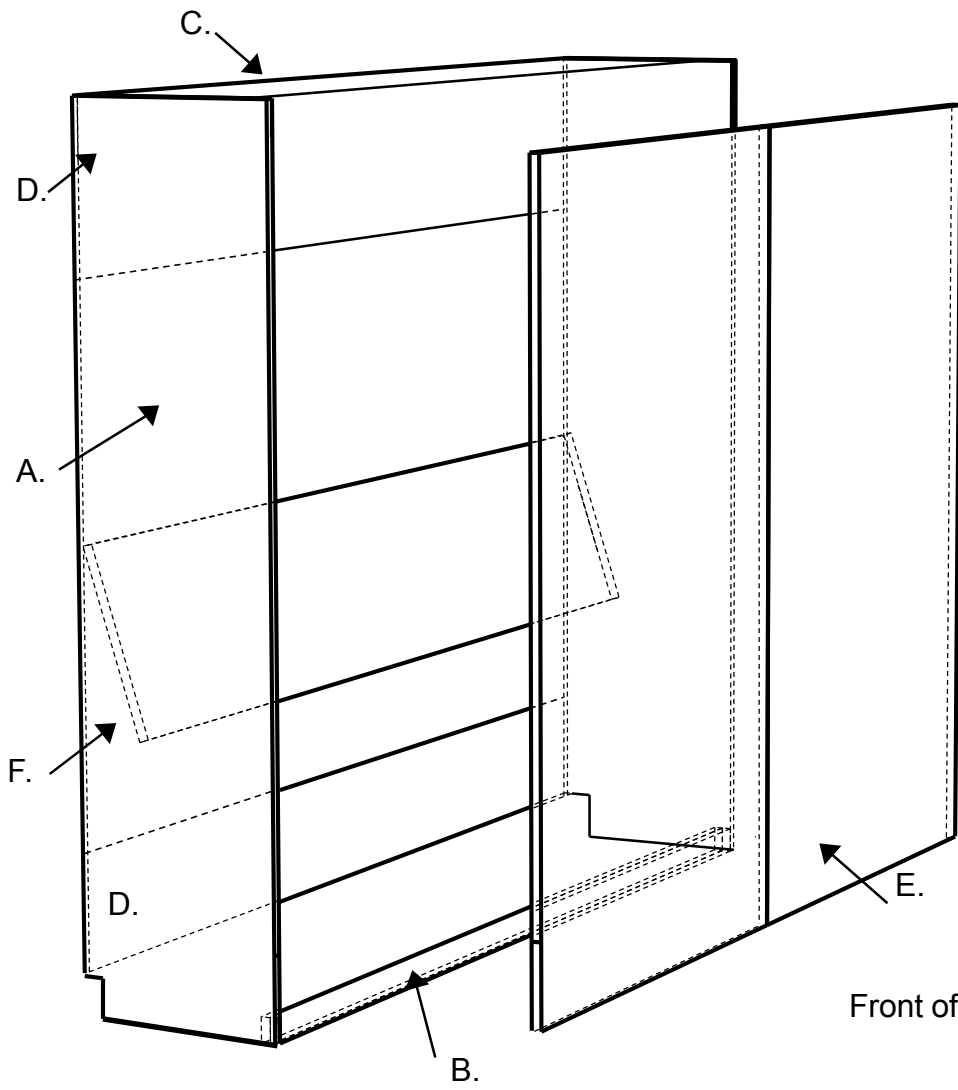

Cabinet Components Description

- E. Face/Base Panels
- A. Side Panels
- C. Top Panel
- D. Back Panels
- B. Kick
- F. Head Board

Front of WallBed

Drawing 2

Alpha Bed Steel Frame - Horizontal Bed Cabinet Cut List

Use a 100mm Kick.

| Single Bed – Finished Size | | Overall Cabinet Dimensions: 1187 h x 2028 w x 410 d | | |
|-----------------------------------|-----------------|--|--------|---------------------|
| Mattress size 990 x 1900 | | Protrusion from wall to foot bed: 1141mm Cabinet | | |
| 300mm max thickness | | Material: 16 MDF or Chipboard | | |
| Quantity | Description | Width | Length | Finish (Tape) Edges |
| 1 | Face/Base Panel | 1062 | 1990 | EAR |
| 2 | Side End Panels | 410 | 1187 | 1 Long |
| 1 | Headboard | 370 | 1996 | 2 Long |
| 1 | Top Panel | 390 | 1996 | 1 Long |
| 1 | Kick | 100 | 1996 | 1 Long |
| 1 | Back | 1051 | 1996 | 1 Long |
| Double – Finished Size | | Overall Cabinet Dimensions: 1567 h x 2028 w x 410 d | | |
| Mattress size 1371 x 1900 | | Protrusion from wall to foot bed: 1637mm Cabinet | | |
| 300 max thickness | | Material: 16 MDF or Chipboard | | |
| Quantity | Description | Width | Length | Finish (Tape) Edges |
| 2 | Face/Base Panel | 719 | 1990 | EAR |
| 2 | End Panels | 410 | 1567 | 1 Long |
| 1 | Headboard | 370 | 1996 | 2 Long |
| 1 | Top Panel | 390 | 1996 | 1 Long |
| 1 | Kick | 100 | 1996 | 1 Long |
| 2 | Back | 350 | 1996 | 1 Long |
| Queen Bed – Finished Size | | Overall Cabinet Dimensions: 1721 h x 2155 w x 410 d | | |
| Mattress size 1524 x 2032 | | Protrusion from wall to foot bed: 1791mm Cabinet | | |
| 300 max thickness | | Material: 16 MDF or Chipboard | | |
| Quantity | Description | Width | Length | Finish (Tape) Edges |
| 2 | Face/Base Panel | 797 | 2117 | EAR |
| 2 | End Panels | 410 | 1721 | 1 Long |
| 1 | Headboard | 370 | 2123 | 2 Long |
| 1 | Top Panel | 390 | 2123 | 1 Long |
| 1 | Kick | 100 | 2123 | 1 Long |
| 2 | Back | 351 | 2123 | 1 Long |

Alpha Balance Lift Mechanism #SBLM - Drill Pattern

Marking the Mounting Holes for the Lift Mechanism 330Leg

Drawing 3.

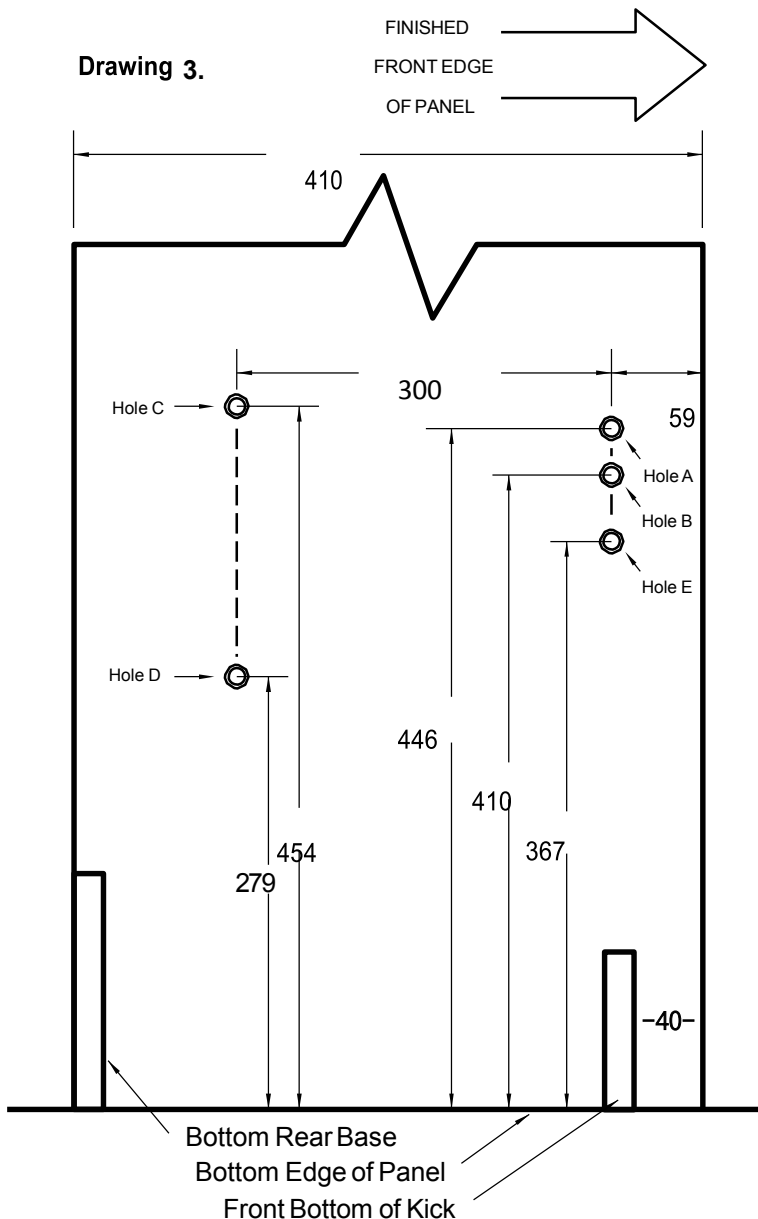

1. Exactly mark the mounting holes on the inside of each side panel.
2. Drill a 1/16" pilot hole for each mounting bolt. Drill the final hole with a 5/16" bit.
3. Counter sink 5/8" on the outside of the panels just deep enough for the 5/16" x 1 1/4" Machine Screws.

NOTE: All location measurements are from the front edge of the Cabinet End Panels. Refer to Drawing 3.

Spring Application Chart

| BED SIZE | BED PANEL MATERIAL | |
|---------------|-----------------------|-----------------------|
| | Plywood Core | Particle Board |
| Single | 4-5 springs per side | 4-5 springs per side |
| Double | 6-7 springs per side | 6-7 springs per side |
| Queen | 7 springs per side | 7 springs per side |
| King | 8- 9 springs per side | 8- 9 springs per side |

After you have completed installing and checking the operation of your bed, you may find it necessary to add or remove springs to achieve the correct lift effort of between 10 kg to 15 kg.

There are nine locations for springs. If the bed requires an even number of springs, do not use the center hole (#5 from the top). If the bed requires an odd number of springs, start with the center hole (#5 from the top) and work outward in both directions evenly.

Hook the springs so the open ends are facing outward. You may have to gently pry up the tension arm and slide the spring under and snap them into place in the proper hole, matching the same numbered hole from the top of the mechanism back plate. You should have an equal number of springs on each side of the center hole.

Use the same number of springs and the same layout on both the left and right mechanisms.

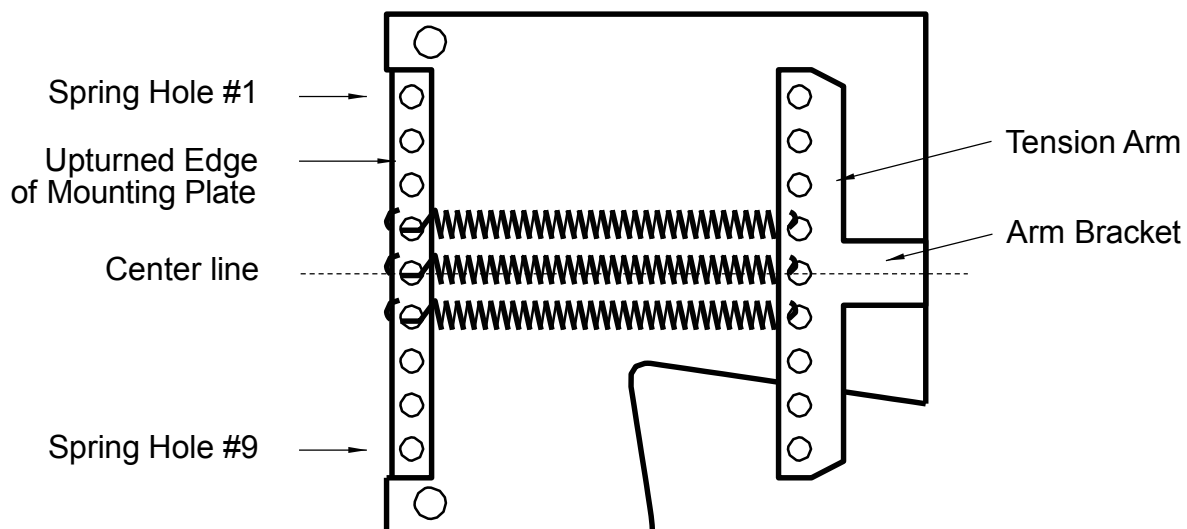

Drawing 5.

Assembling the Bed Cabinet

For easier final wall mount you should assemble bed cabinet in the room where it will be used.

1. Fit the springs to both spring lift mechanisms as per instructions on page 9.
2. Attach the Spring Lift Mechanisms to the Side Panels **(A)**.
3. Use 3 of the 25mm Hex Head bolts supplied in supplementary hardware bag in the front 3 counter sunk holes in the side panels. Tighten with the nylon nuts (16) supplied in hardware card 2#
4. Then using 2 each of the original packaged 30mm Hex Head bolts (10) in hardware card 2# for the rear counter sunk holes also tighten with nylon nuts (16)
5. Repeat for both sides.

IMPORTANT- *If you using 16mm board for your cabinetry from it is recommended that you replace the front 3 x 30mm supplied hex bolts with 25mm. Do this for both sides of the spring lift mechanisms as per step 3 of these instructions. This will prevent any chance of the hex bolt hitting on the spring arm when opening and closing the face/base panel*

- Assemble the 2 x Side Panels **(A)** to the Top Panel **(C)** the back edge of the top panel should be set flush with both the top & back of each side panel.
- The Top Panel is set back 20mm from the front edge of the side panels.
- Attach the bottom back panel **(D)** 30mm up from the top of the skirting cut out.
- Attach the Kick **(B)**
- Installing the Bed Head Board **(F)** this should be done prior to installing the Bed Panel or attaching the bed cabinet to the wall. Measurements given are based on a 27cm deep mattress. You will need to increase or decrease this depending on the mattress depth thickness.
- Locate the mounting position of the headboard by marking the left and right side panels as per drawing 7.
- Use the angle brackets (2 each side). Be sure the top bracket is set low enough not to protrude beyond the back of the cabinet.
- Use the Pan Head Screws to fix these brackets.
- The Headboard location may vary slightly; just be sure it is secure and at the approximate 76mm angle from the back edge.

Alpha Bed Cabinetry

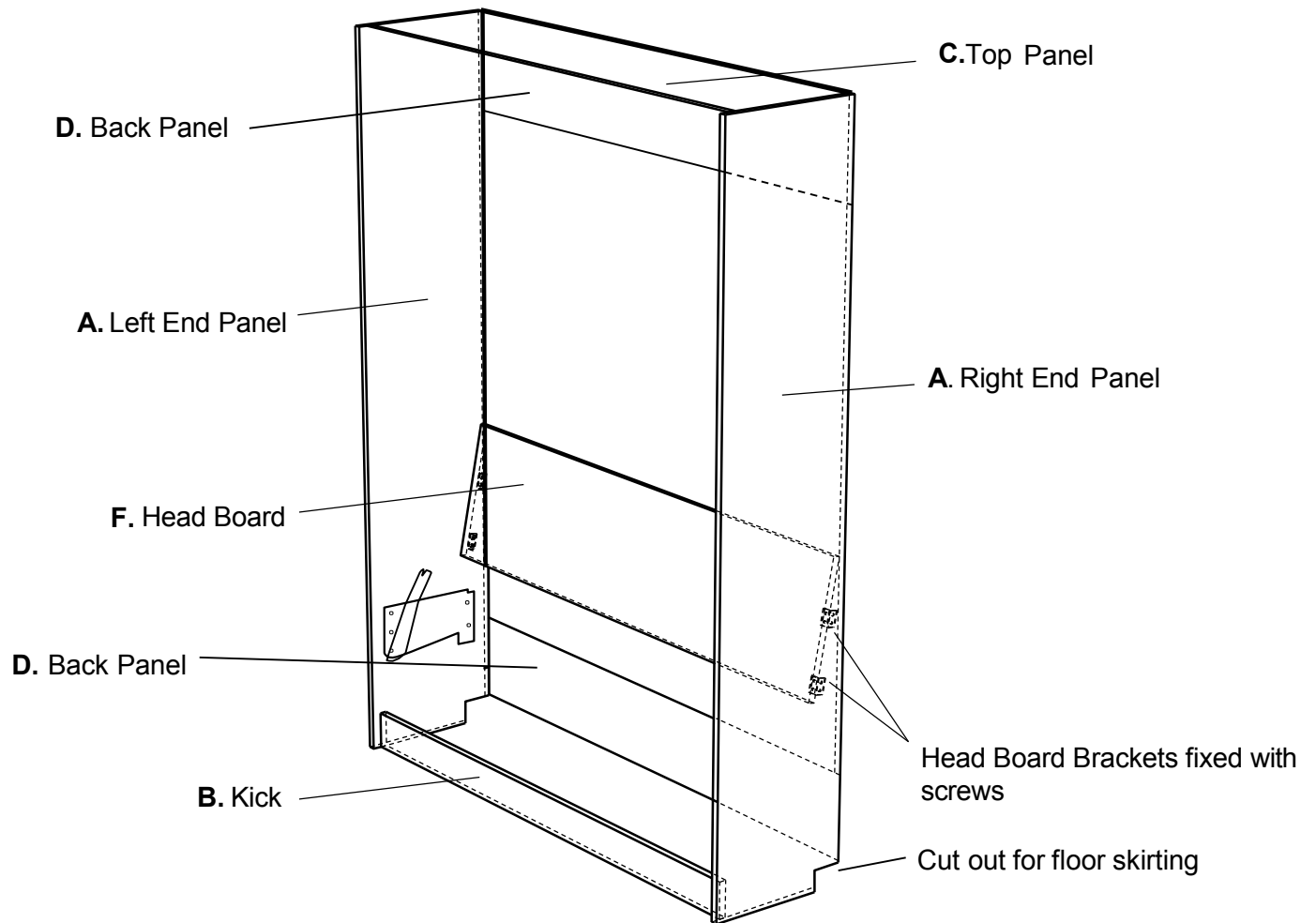

Drawing 6.

Assembling the Bed Cabinet (cont.)

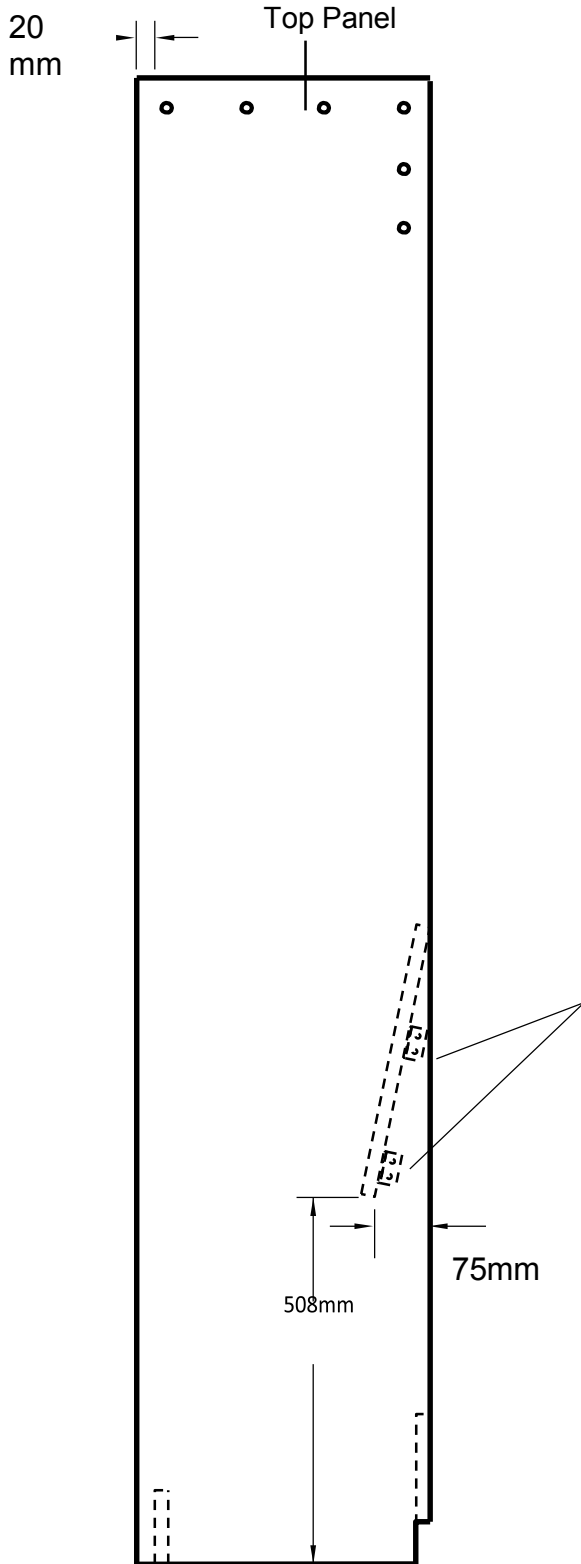

Drawing 7.

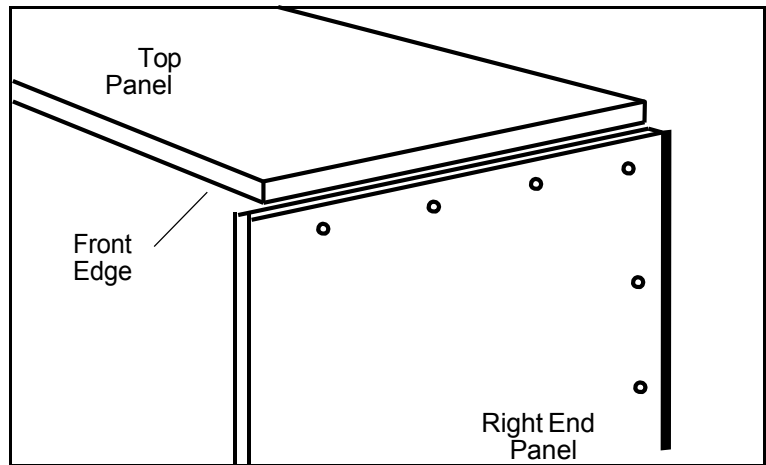

Drawing 8.

Attach Bed Cabinet Securely to Wall

Hints: If the room is carpeted you may raise the kick up to clear the carpet. More than 15mm will obstruct the operation of the bed.

1. Place cabinet against wall. Make sure the cabinet is level and square. Measure diagonally to be sure of square. Bed will not operate if cabinet is not square. Check also for square from front to back as well as side to side. Use packers where necessary.
2. Prior to placing cabinet against the wall, locate 3 studs or other wall frame members at the level of the Top panel (Refer to Drawing 9)
The cabinet must be secured to wall studs or other wall structural members using 40mm x 40mm L-Brackets & the 50mm timber stud fixing screws.

Alert: If the wall is not a wood stud wall, then you will need to use metal stud screws, toggle bolts or concrete expansion bolts as necessary. THESE ARE NOT THE SCREWS SUPPLIED.

3. Now that the cabinet is square and plumb, use one 50mm flat head wood screws in each of three “L” brackets to attach to studs.
4. Re-check the wall bed cabinet is square and plumb and then secure L-Brackets to the Top panel (C) using the Dome Head wood screws.

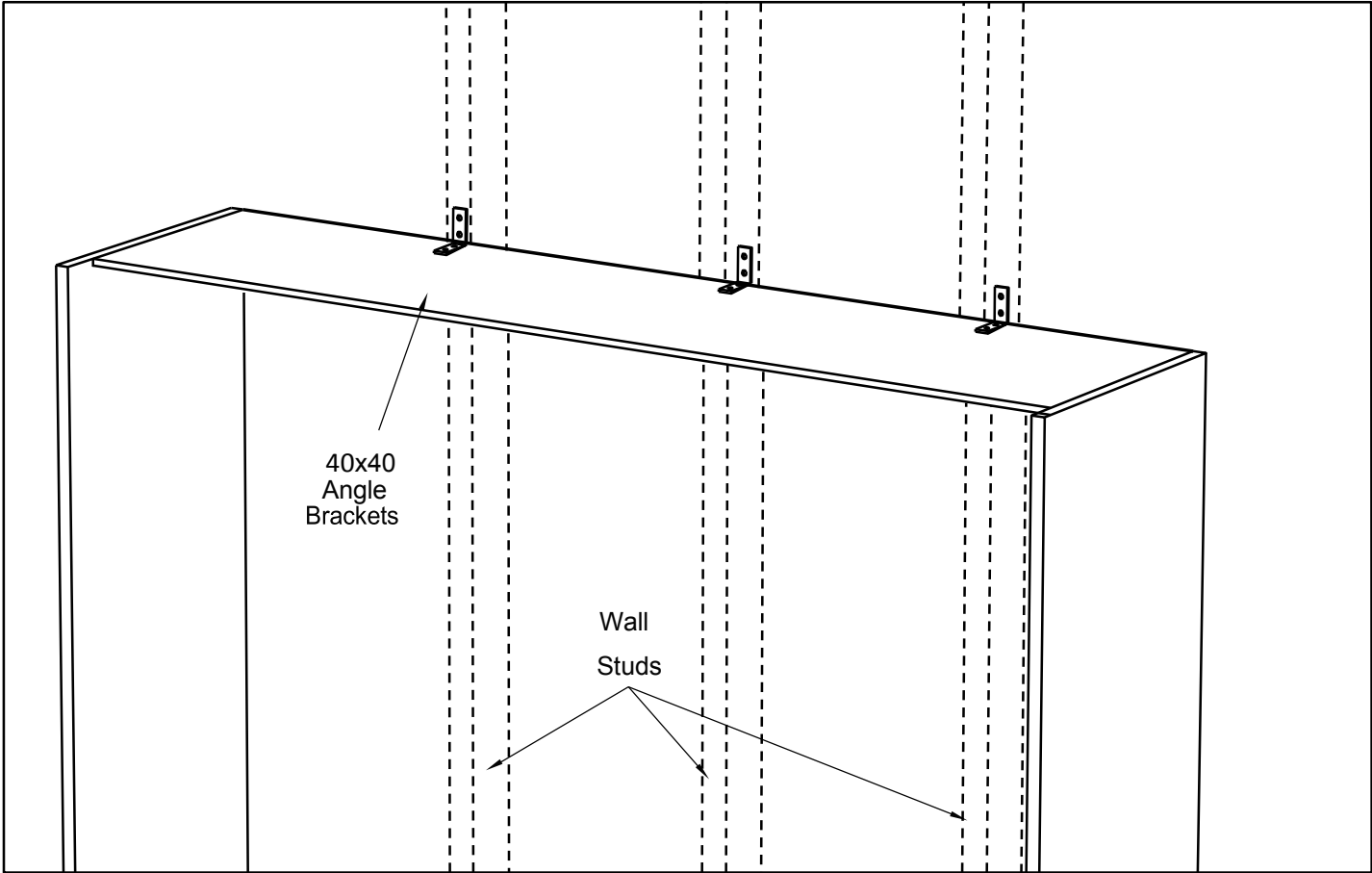

Left
End Panel

Drawing 9

Right
End Panel

Assemble Steel Bed Frame to Face Panels

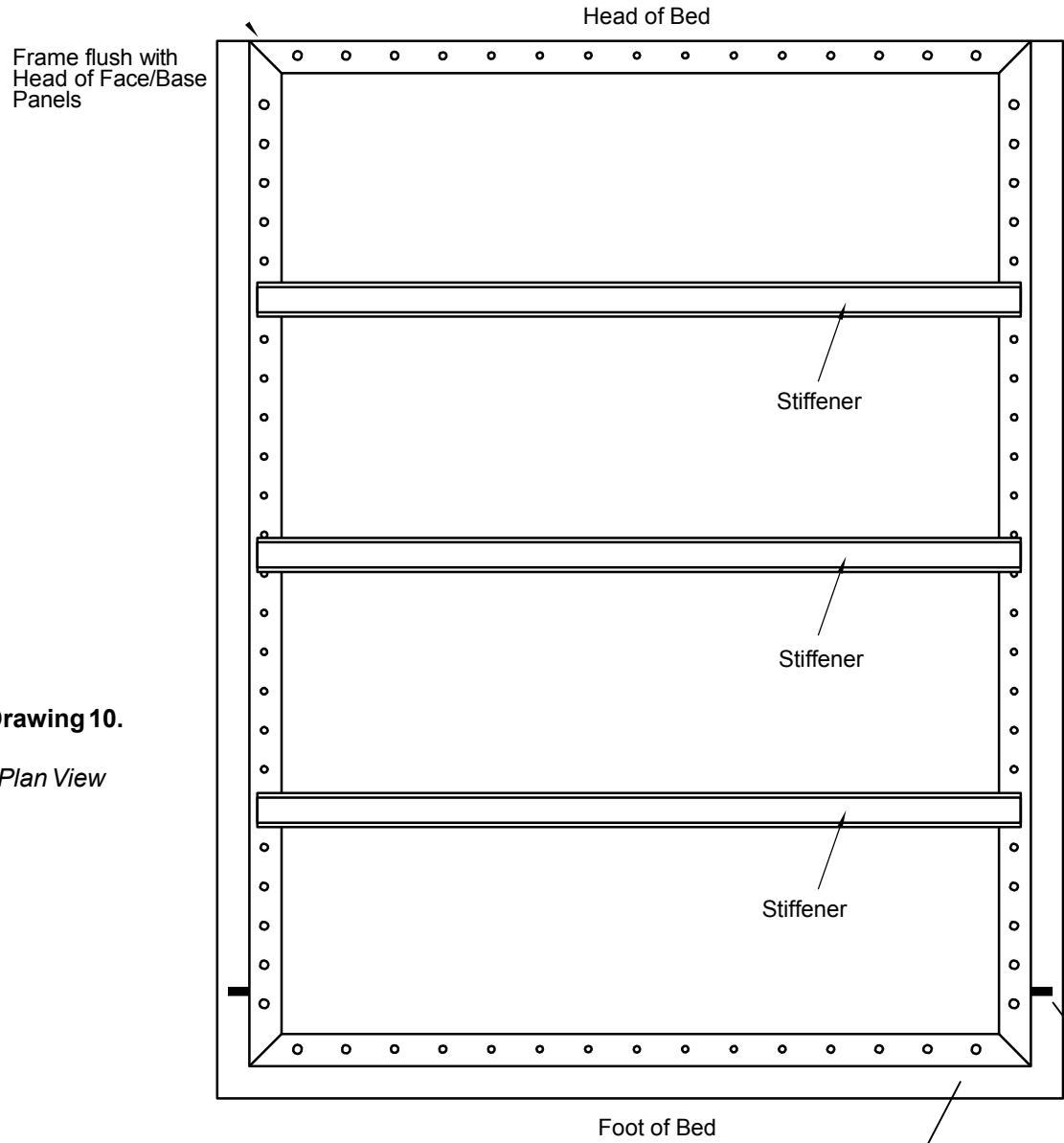

Drawing 10.
Plan View

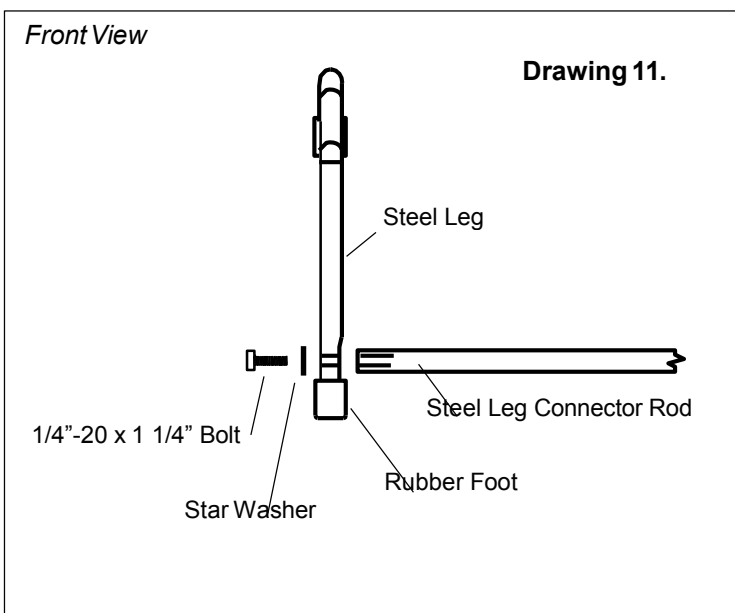

Drawing 11.

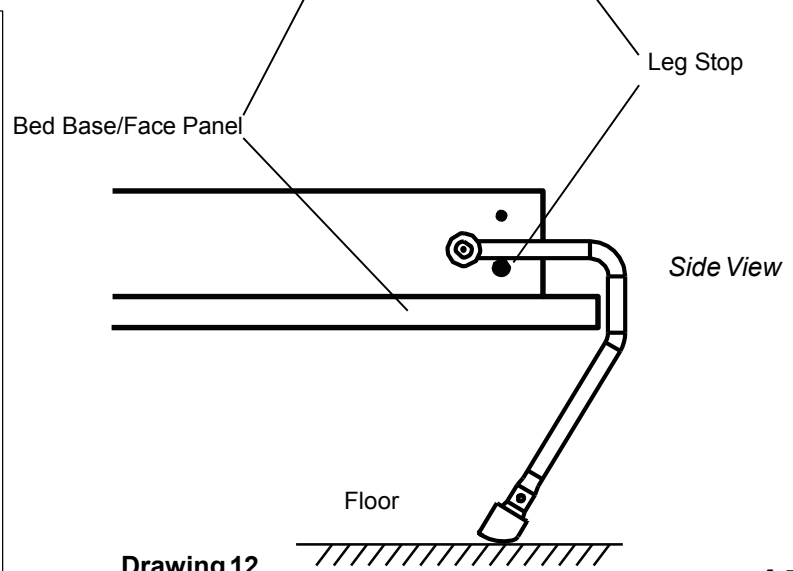

Drawing 12.

Assemble the Bed Face/Base Panels

Step 1:

Completely assemble the Steel Bed Frame. Use the small corner brackets and the 3/16" x 1/2" black bolts provided. (**Hardware Bag # 3**) To join the 4 outer steel frames together. Refer to Drawing 12 to properly place the leg stops at outer right and left bottom holes at the foot of the bed frame.

Step 2:

Place the Bed Face/Base Panels down on a non-scratch surface such as a carpet or blanket. Place a small washer between the two panels to create an equal gap. Place one near the top & one near the bottom. Ensure you remove these once you have secured the steel frame in place on each corner.

Step 3:

Position the Steel Bed Frame on the Bed Face/Base panels with the Head Frame section flush with the head end of the Bed Face/Base Panels. *Refer to Drawing 10.* Place the Steel Bed Frame so it is centered on the Bed Face/Base Panels; you will have approximately 24mm space from the edge of the bed frame to the panel edges right and left and at the bed foot.

To ensure the Steel Bed Frame remains square start fixing the frame to the Base/Face panel in each corner first at the head of the frame.

If 16mm board is being used for the Base/Face panels it is recommended that you replace the Steel Frame Fixing screws 5/8" supplied with 1/2" screws. We also recommend that you pre-drill the holes for all of the steel frame fixing screws. This will reduce the risk of any "bulging effect" of the timber thru the Base/Face panel.

Step 4:

Re check the measurements at the foot end of the Steel Bed Frame to ensure it is still square on the Face/Base panels. Once you have checked the measurements attach two screws to either side of all of the frame corners.

Remove the two washers then continue to fix in all of the Steel Bed Frame screws.

Note: It is very important to have the Bed Frame centered on the bed Base/Face panels. Any error will be noticed in the vertical sight lines when the bed is closed.

Step 5:

Three steel stiffeners are provided for all beds. These notched stiffeners should be located and attached to divide the Steel Bed Frame length into four equal sections. Use caution not to damage Bed Face / Base panels by putting screws in too far into the recessed areas.

Step 6:

Attach the Nylon Web Strap approximately 457mm from the foot of the bed. Use one of the existing screw holes & screw that fixes the steel frame to the Base/Face panel. This strap will assist in securing the mattress when the bed is in the closed position.

Setting the Lift Mechanism

* *WallBeds Australia recommends eye protection is worn whilst setting the Spring Lift Mechanism*

Holding one foot against the bottom front edge of the side panel and using the PVC tube supplied, lever the tension arm out until you can set the arm lock to the hex nut at the hole A (see drawing 13.) This is the hex nut at the top front corner of the mechanism. *This may also require the assistance of a helper to achieve this step.*

Caution:

Have a helper assist in the setting of the lift mechanism and loading of the bed base / face panel. **Do not reach behind the tension arm when you are doing the setting procedure.**

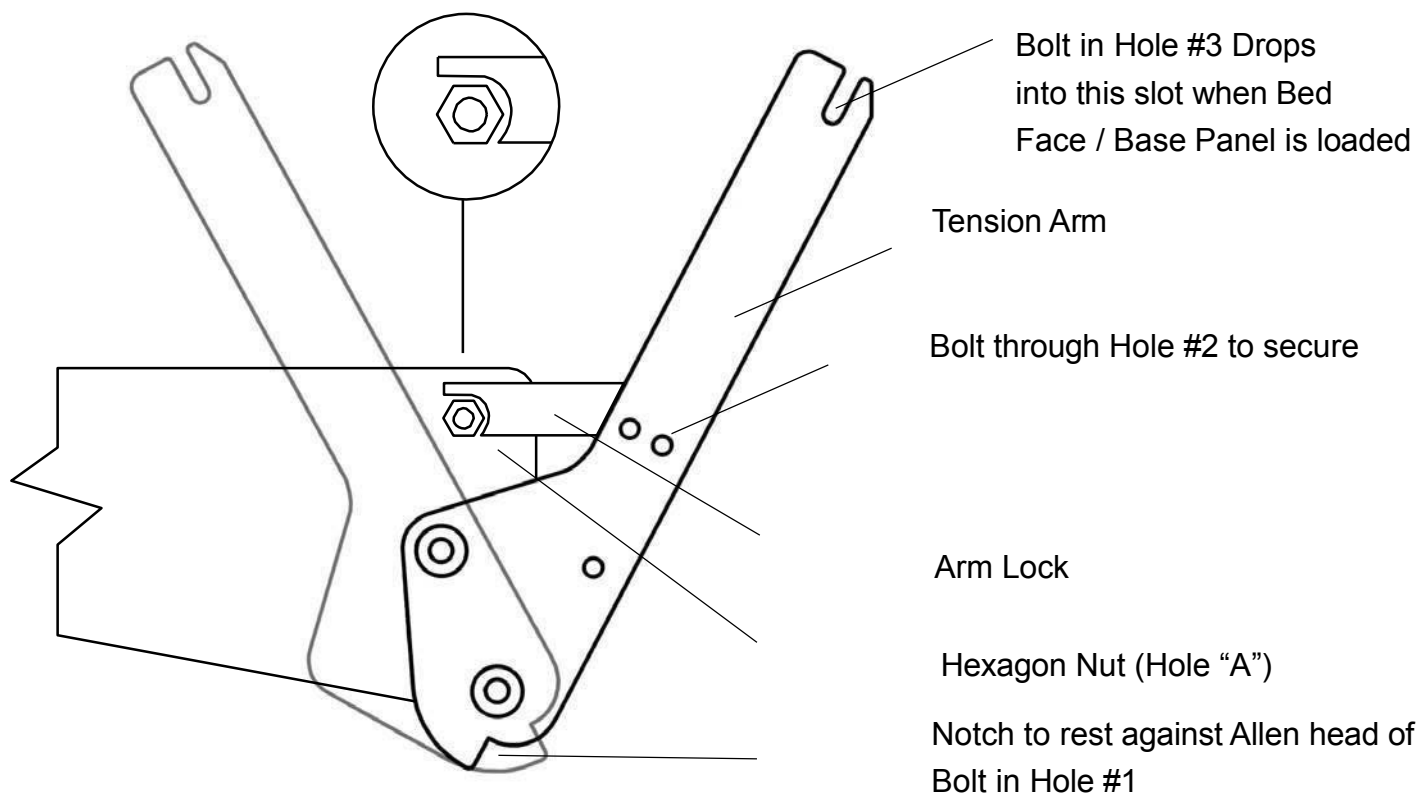

Drawing 13.

Install the Bed / Base Panel Unit

1. Insert two 5/16" x 3/4" Head Bolts from the outside through Hole #3 (see drawing 14) put 5/16" Nylock nuts on these bolts only until the nut is flush with the bolt end.
2. Insert the two Allen Head Bolts from the outside of the Frame through Hole #1 (see drawing 14) use 5/16" Nylock nuts and securely tighten. Stand the Bed / Base Panel in vertical position between the tension arms, lift evenly until the bolt in Hole #3 drops in the notched end of each tension bar.
3. Gently tilt the bed face toward you until the Allen Bolts in Hole #1 are completely seated in the bottom notch of the tension bar. Insert the remaining 5/16" x 3/4" Head Bolts in Hole #2, tighten bolts #1 and #2 securely.

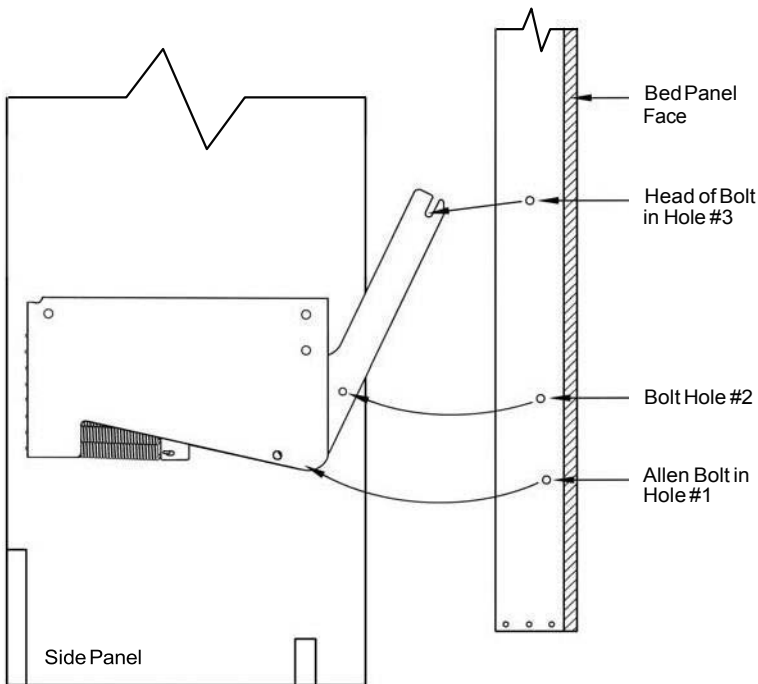

Drawing 14.

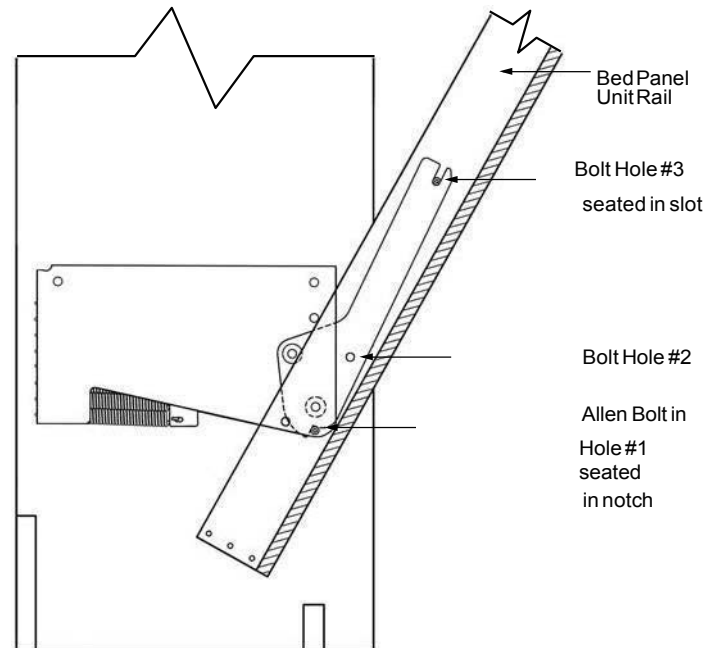

Drawing 15.

4. When all bolts are securely tightened, you may tilt the panel outward to approximately 45 degrees to release the arm locks. You will hear a click as they disengage.
5. Hold the Face Panel securely, Do Not let it slam shut. Balance is not achieved until the mattress is loaded in the bed.
6. Leveling of the bed cabinet is essential. Check the level both side to side and front to back. Proper leveling will facilitate proper closure and exact sight lines of the fit of the Face Panel to the Cabinet.

Install Handles, Legs, Mechanism Covers, & Mattress

1. Position and secure the handle for ease of operation at your preferred height.
2. Install legs with the nylon washers on the inside and outside of the steel rails. Tighten the nylon nut to have a small amount of friction when leg assembly is rotated from the up to down position.

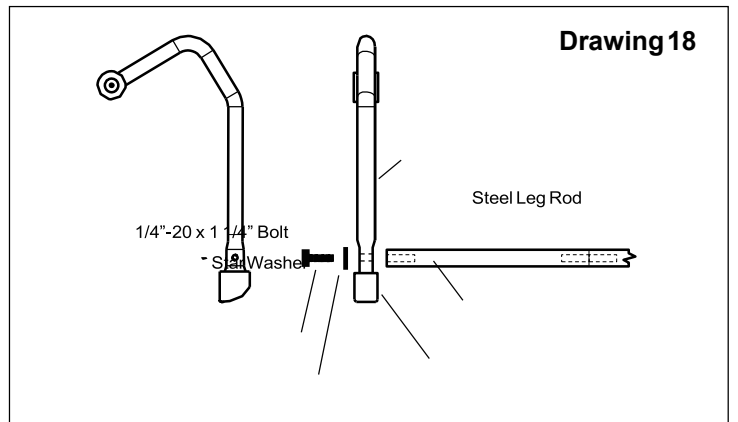
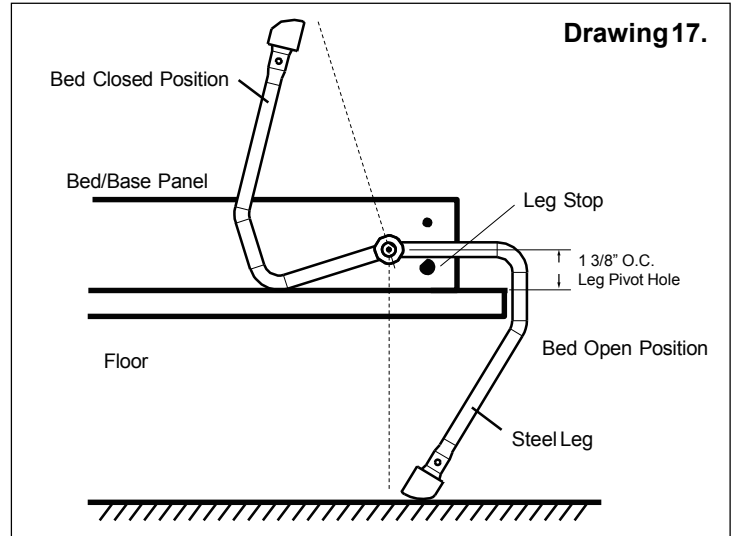
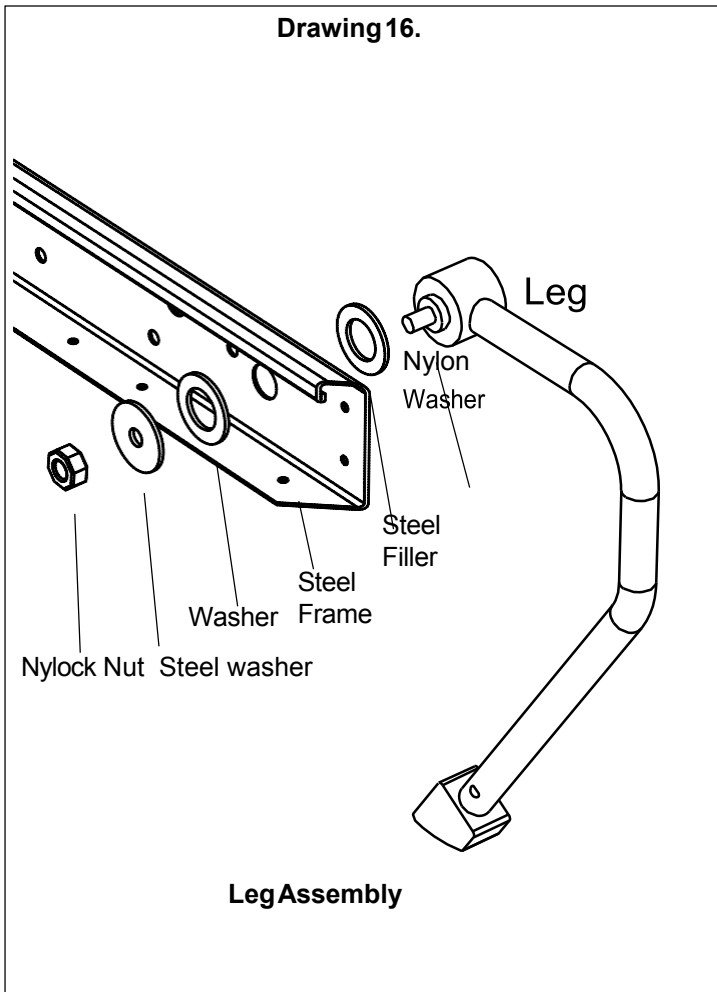

3. Install leg connector rod between legs and secure with 1/4" x 1 1/4" Hex head bolts and star washers. Be sure they are securely tightened so not to become loose.
4. Attach the powder coated spring mechanism covers in place - **secure these with #8 x 1 1/4" black wood screws through the hole in each of the cover plates. These screws will fix into the timber side panels of the bed.**
5. Install mattress and secure with previously installed Velcro straps. Cut the excess Velcro to leave about 305mm of overlap.

Follow up to Initial Assembly

- Level or square problems with the Base / Face fitting into Cabinet. - *Nudge base of Cabinet at the floor level - or use packers under the End Panels.*
- If bed is too heavy to operate - *Remove Base / Face Panel and add springs.*
- Base / Face panel slams shut or is difficult to open - *You may decide to use one more or less spring(s) on the Lift Mechanism. To achieve this it will require you to remove the bed Face/ Base panel for ease of access to the springs.*

**WALL
BEDS**
AUSTRALIA
1300 663 660